

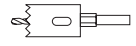
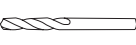

# Scanstrut Installation Instructions SC30

## Tools Required

	ø30-50mm (1 1/4"-2")
	Drill bits to suit Radome fasteners & drainage hole if needed.
	Power drill

## Parts Required

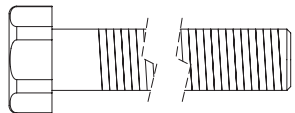
	4x M8 Fasteners (length to suit mounting area)
---	--

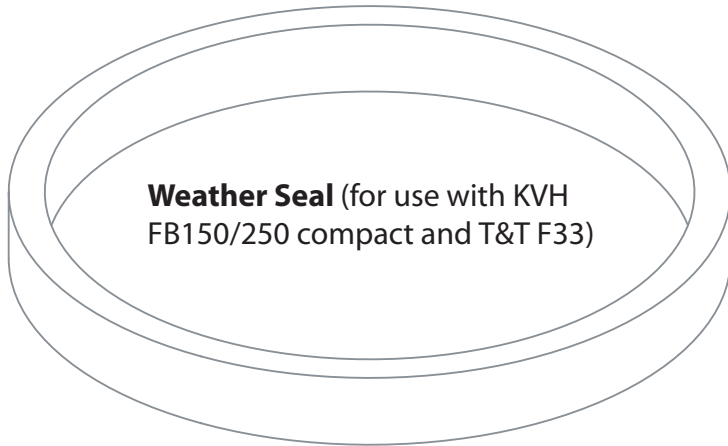

**Drainage hole** (ø3mm (1/8"))  
to be drilled when fitting  
FB150/250 compact, or  
Thrane & Thrane F33

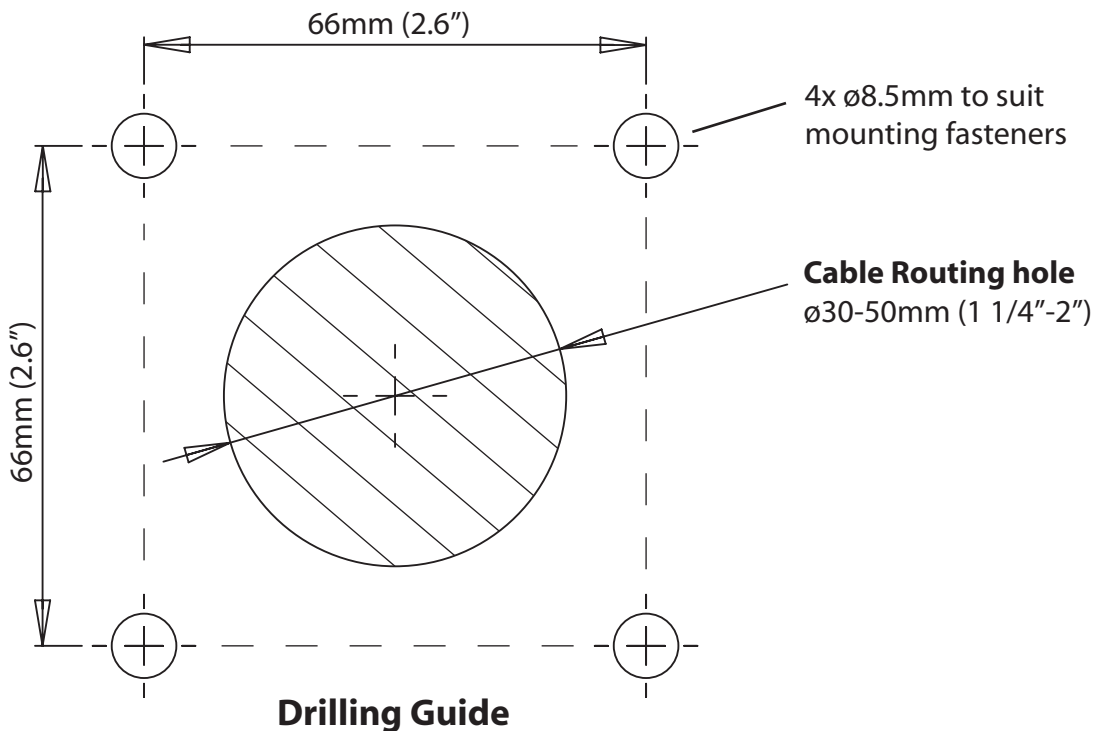
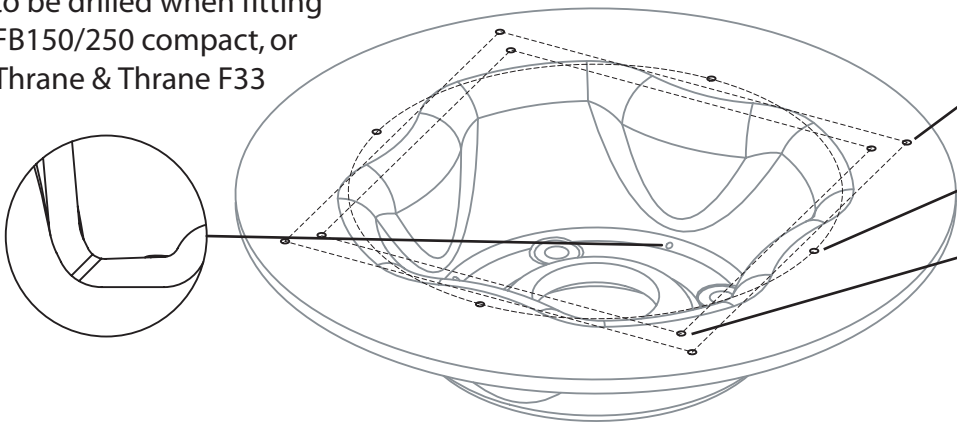

## **Satcom Mount - SC35**

### **Installation Instructions**

#### **SC35 Kit Contents:**

- SC35 Composite Moulding
- Expanded Polyethylene Seal
- Cable gland (optional)

- 4x 8mm Stainless Steel bolts, washers and nuts to attach SC35 to deck/arch or Pole Top. (Length to suit deck/ arch/ Pole top).
- 13/32" / 16.5mm Drill (for optional cable gland)
- 9/32" / 8.5mm Drill.
- Hole Cutter for cable loom; approx 2" / 50mm diameter.

#### **Also Required:**

#### **Drilling guide to mount the SC35**

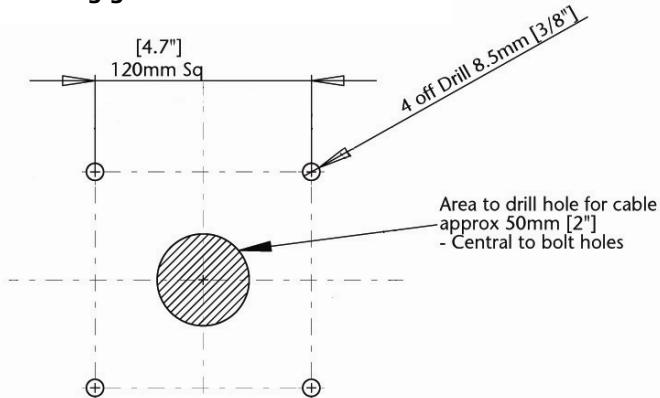

**Figure 1**

#### **Cable gland hole location**

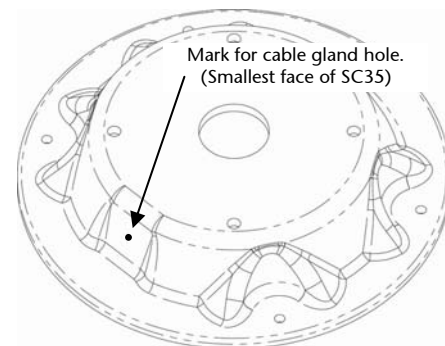

**Figure 2**

**Before fitting the SC35, decide whether you wish to lead the cable outside the SC35 and back through the cable gland or doubled back under the dome and through the inside of the SC35.**

#### **To fit the cable gland (if required):**

1. Drill a 13/32" / 16.5mm hole in the smallest face of SC35 with the hole centre indicated by the small dent in the SC35 - (**See figure 2**).
2. Insert the gland body into the 16.5mm hole. Fit the seal and nut screwed to the inside face. The connector may need to be removed from the cable so that it can be fed through the gland. After the gland has been fitted continue with the installation.

#### **If you are fitting to an arch / deck:**

1. Drill the arch to match SC35 mounting hole pattern and central cable exit (**figure 1**).
2. Using 4 x M8 Stainless Steel Bolts fasten the SC35 into position.
3. Thread cable loom up through the arch, SC35 (cable gland) and connect to Sat Dome.
4. Using the 4 feet of the dome position the Expanded Polyethylene Seal under the Sat Dome and position the Dome onto the SC35.
5. Fasten the dome to the top plate of the SC35 with the bolts supplied with the sat Dome ensuring the seal compresses so that the dome mounting feet are touching the SC35 moulding.

#### **If you are fitting to the top plate of a pole mount:**

1. Install your pole mount as instructed.
2. Follow 2 – 5 as explained in the arch/deck fitting (see above). At 4, thread the cable loom up through the pole system, SC35, (cable gland) and connect to your Sat Dome.

**Satcom Mount - SC45 / SC65**  
**Installation Instructions**

**SC45/SC65 Kit Contents:**

SC45/SC65 Composite Moulding  
Expanded Polyethylene Seal

**Also Required:**

4 x M8 Stainless Steel bolts, large washers and nuts to attach SC45 to deck/arch or Pole Top.  
Length to suit deck/arch/Pole top thickness.  
8.5mm Drill.  
Hole Cutter for cable loom; approx 50mm dia.

**Drilling Guide:**

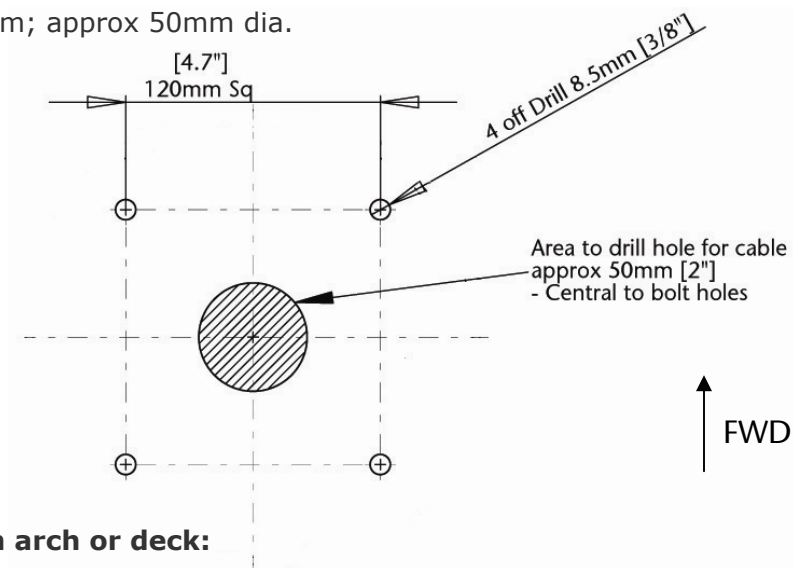

**Fitting SC45/SC65:**

**If you are fitting to an arch or deck:**

1. Drill holes in arch to match SC45/SC65 and central cable exit – See drilling guide.
2. Using 4 x M8 Stainless Steel Bolts fasten the SC45/SC65 into position.
3. Thread the cable loom up through the arch, SC45/SC65 and connect to your Sat Dome.
4. Using the 4 feet of the dome position the Expanded Polyethylene Seal under the Sat Dome and position the Dome onto the SC45/SC65.
5. Fasten the dome to the top plate of the SC45/SC65 with the bolts supplied. Fully tighten ensuring the seal compresses so the Domes rubber feet are sitting onto the SC45/SC65 moulding.

**If you are fitting to the top plate of a pole installation:**

1. Install your pole as instructed.
2. Place SC45/SC65 moulding onto the top plate of the pole.
3. Using 4 x M8 Stainless Steel Bolts fasten the SC45/SC65 into position.
4. Thread the cable loom up through the pole system, SC45/SC65 and connect to your Sat Dome.
5. Using the 4 feet of the dome position the Expanded Polyethylene Seal under the Sat Dome and position the Dome onto the SC45/SC65.
6. Fasten the dome to the top plate of the SC45/SC65 with the bolts supplied. Fully tighten ensuring the seal compresses so the Domes rubber feet are sitting onto the SC45/SC65 moulding.

## **Satcom Mount - SC45R** **Installation Instructions**

### **SC45 R Kit Contents:**

SC45 Composite Moulding  
Expanded Polyethylene Seal 2mm thick, double sided adhesive.  
45STV Adapter Plate

### **Also Required:**

4 x M8 Stainless Steel bolts, large washers and nuts to attach SC45 to deck/arch or Pole Top.  
Length to suit deck/arch/Pole top thickness.  
8.5mm Drill.  
Hole Cutter for cable loom; approx 50mm dia.

### **Drilling Guide:**

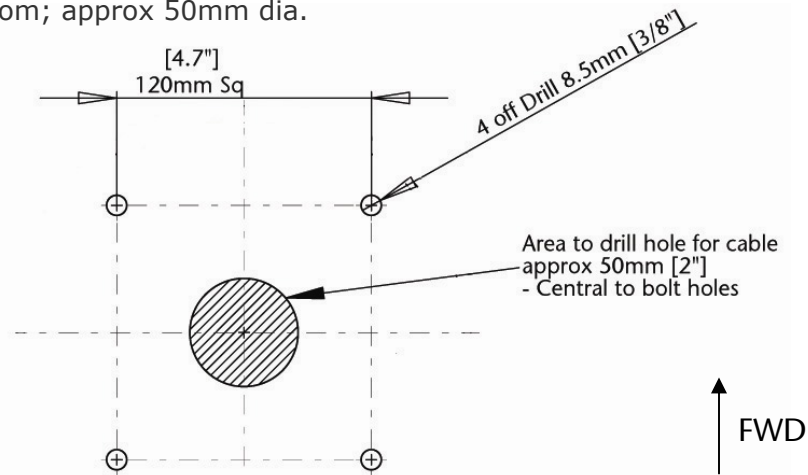

### **Fitting SC45:**

#### **If you are fitting to an arch or deck:**

1. Drill holes in arch to match SC45 and central cable exit – See drilling guide.
2. Using 4 x M8 Stainless Steel Bolts fasten the SC45 into position.
3. Peel off 1 side of backing paper and adhere the Expanded Polyethylene Seal to the underside [side that will fit onto SC45 composite moulding] of the 45 STV Adapter.
4. Peel off remaining backing paper and place the 45STV adapter into the SC45, locating the base recesses over the SC45's M8 fixing bolts and aligning the holes in the top plate, ensuring the 45STV adapter is adhered to the SC45.
5. Thread the cable loom up through the arch, SC45, attached 45STV adapter plate and connect to your Sat Dome.
6. Ensure the seal supplied with your 45STV is fitted correctly and fasten the dome to the top plate of the SC45 and 45STV assembly with the bolts supplied. Fully tighten ensuring the seal compresses so the Domes' rubber feet are sitting onto the 45STV plate.

#### **If you are fitting to the top plate of a pole installation:**

1. Install your pole as instructed.
2. Place SC45 moulding onto the top plate of the pole.
3. Using 4 x M8 Stainless Steel Bolts fasten the SC45 into position.
4. Peel off 1 side of backing paper and adhere the Expanded Polyethylene Seal to the underside [side that will fit onto SC45 composite moulding] of the 45 STV Adapter.
5. Peel off remaining backing paper and place the 45STV adapter into the SC45, locating the base recesses over the SC45's M8 fixing bolts and aligning the holes in the top plate, ensuring the 45STV adapter is adhered to the SC45.
6. Thread the cable loom up through the arch, SC45 and connect to your Sat Dome
7. Ensure the seal supplied with your 45STV is fitted correctly and fasten the dome to the top plate of the SC45 and 45STV assembly with the bolts supplied. Fully tighten ensuring the seal compresses so the Domes' rubber feet are sitting onto the 45STV plate.

Appendix 1. - Additional stages for fitting a CAMOS CSA-450, CSA-600, Naval Nav Sat 60 or Oyster TRX7.

To fit a CAMOS CSA-450, CSA-600, Naval Nav Sat 60 or Oyster TRXT, you need to drill additional holes. You do not need the supplied Foam Seal, as the dome will come supplied with its own seal.

You will need to use the drilling template below. Use the template four times, aligning where each existing pre-drilled hole is.

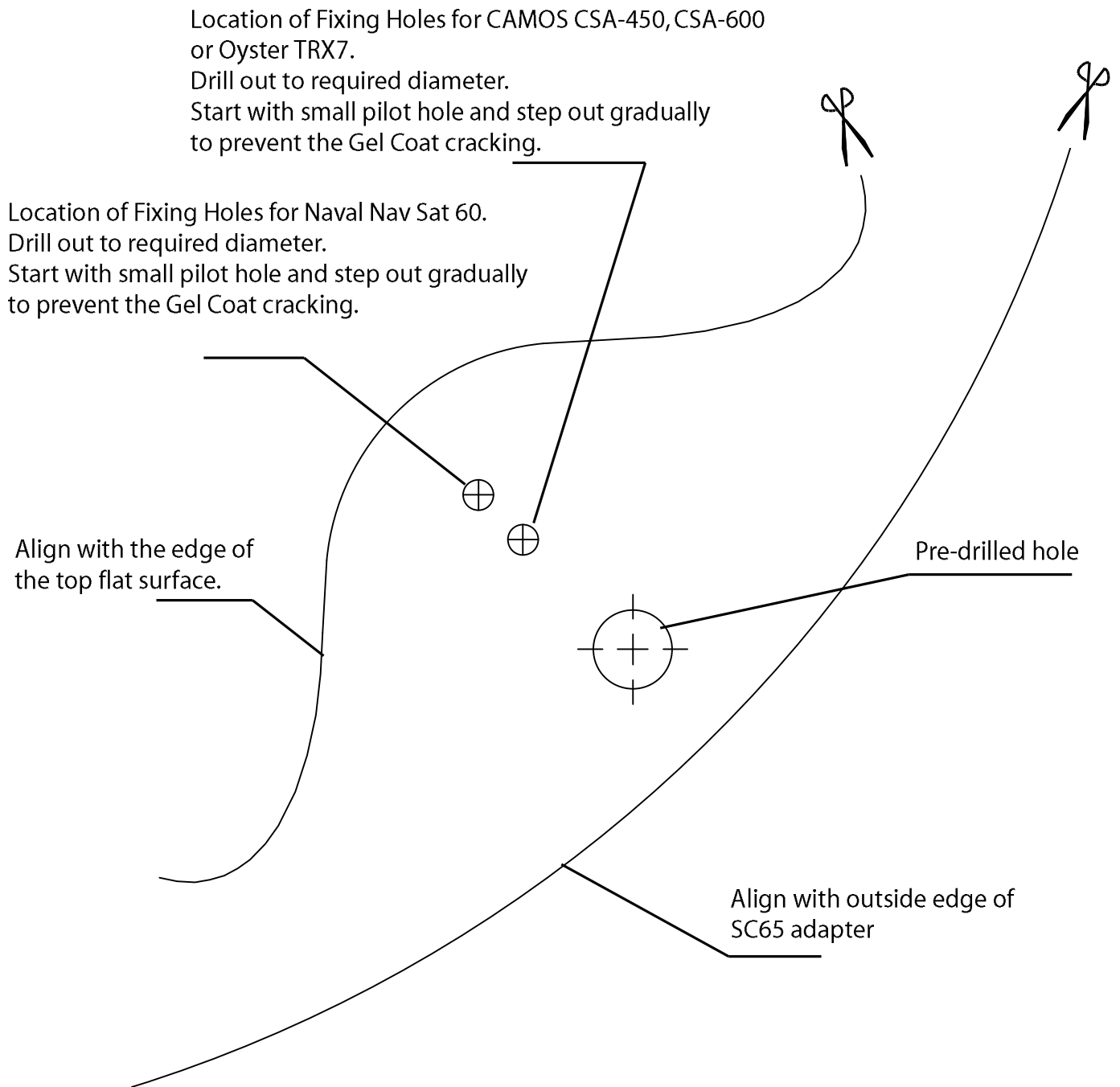

**Satcom Mount - SC80**  
**Installation Instructions**



**Kit Contents:**

- 1 x SC80 adaptor
- 1x base seal
- 1x KDL Gland
- 4x shakeproof washers
- 5x cable grommets for KDL Gland
- 4x blanking grommets for KDL Gland
- 4x M5 x 25 Socket Cap Screw
- 4x M5 S/S Shake Proof washer

**Also required:**

- 4x M10 Stainless Steel bolts and large washers to attach the G8/F77 (provided with antenna).
- 4x M10 Stainless Steel bolts, large washers and nuts to attach SC80 to deck/arch. (Length to suit deck/arch thickness).
- 11mm / 5/16" Drill.
- Hole cutter for cable loom; approx Ø60mm/2-1/4".

The following instructions are a guide to fitting a KVH G8/F77 dome with Scanstrut SC80 adaptor.

1. Position SC80 in desired position on the deck/arch. Mark and drill M10 clearance holes through the fixing holes in the base.
2. Mark out and cut suitable access hole for the G8/F77 cable loom. This will be routed through the deck/arch and out through the Gland plate on the front of the SC80.

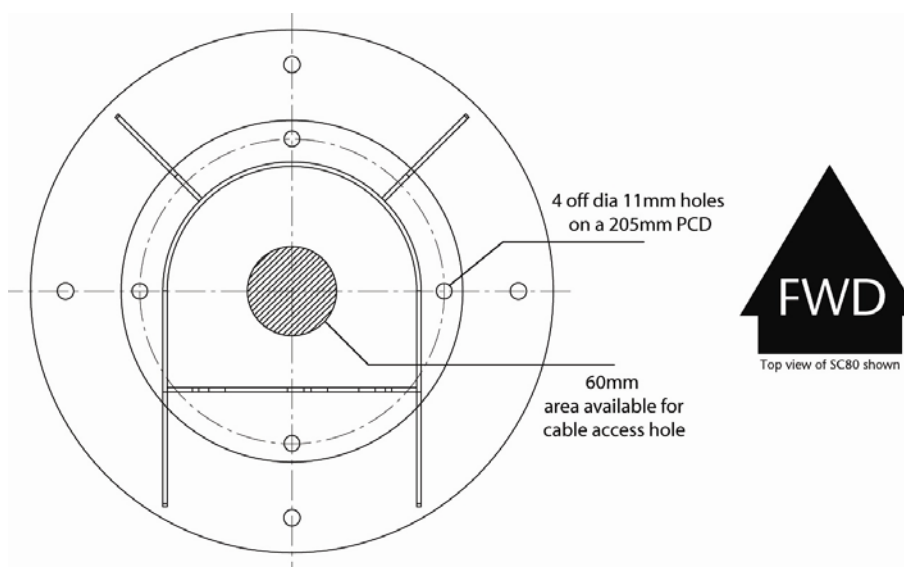

3. The cable gland seal needs to be fitted to the face of the SC80 making sure the holes in the SC80 and rubber seal are lined up properly. This should be done before continuing to the next stage.
4. Fix the SC80 and base seal to the deck/arch using M10 bolts.
5. Position the G8/F77 on top of the SC80, ensuring the feet align with the holes in the top plate.
6. Attach the G8/F77 to the SC80 using M10 bolts provided with antenna and fully tighten; the G8/F77's rubber feet should compress slightly. We also recommend using large washers if possible.

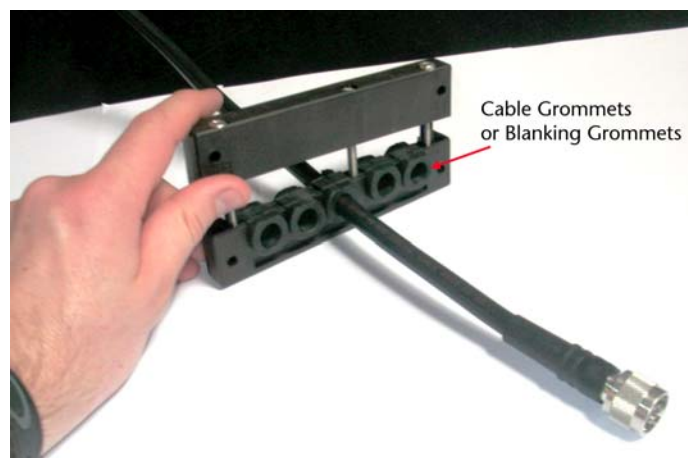

7. Feed the cable loom up through the access hole in the deck/arch, through the hole in the bottom plate of the SC80, and then through the cut-out for the KDL gland.
8. Unbolt the M5 bolts holding the KDL Gland together to open up the KDL Gland.
9. Assemble KDL Gland and Cables. The main Power and Data cable should be central in the Gland, RF cables to the side. Any spare holes to be filled with blanking grommets provided.
10. Loosely tighten the KDL Gland assembly allowing the assembly to slide over the cables so that the correct cable lengths can be set.
11. Locate the KDL Gland into position and set cable lengths so that the access hatch on the G8/F77 can be opened and allowed to freely rest on the deck/arch for maintenance to the antenna, without having to remove the Gland Plate
12. Once the cable lengths are set fully tighten the KDL Gland and attach to the SC80 cut-out plate with the M5x25 and shakeproof washers.